

Approved by:
Checked by:
Issued by:

SPECIFICATION

PRODUCT: Relative Humidity&Temperature Sensor System

MODEL : RHTS02/ RHTS 02A

SENSLED MICROELECTRONICS .Co. Ltd

**Evaluation Kit
Available**

- Relative humidity and temperature sensors
- Dew point
- Fully calibrated, digital output
- Excellent long-term stability
- No external components required
- Ultra low power consumption
- Surface mountable or 4-pin fully interchangeable
- Small size
- Automatic power down

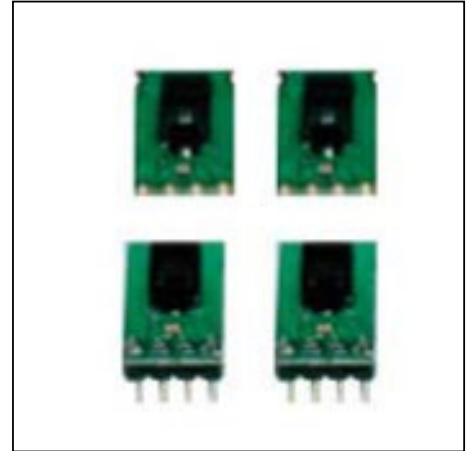

RHTS02/RHTS02A Product Summary

The RHTS02/02A is a single chip relative humidity and temperature multi sensor module comprising a calibrated digital output. Application of industrial CMOS processes with patented micro-machining (CMOSens® technology) ensures highest reliability and excellent long term stability. The device includes a capacitive polymer sensing element for relative humidity and a band gap temperature sensor. Both are seamlessly coupled to a 14bit analog to digital converter and a serial interface circuit on the same chip. This results in superior signal quality, a fast response time and insensitivity to external disturbances (EMC) at a very competitive price. Each RHTS02/02A is individually calibrated in a precision humidity chamber. The calibration coefficients are programmed into the OTP memory. These coefficients are used internally during measurements to calibrate the signals from the sensors. The 2-wire serial interface and internal voltage regulation allows easy and fast system integration. Its tiny size and low power consumption makes it the ultimate choice for even the most demanding applications. The device is supplied in either a surface-mountable LCC (Leadless Chip Carrier) or as a pluggable 4-pin single-in-line type package. Customer specific packaging options may be available on request.

Applications

- _ HVAC
- _ Automotive
- _ Consumer Goods
- _ Weather Stations
- _ Humidifiers
- _ Dehumidifiers
- _ Test & Measurement
- _ Data Logging
- _ Automation
- _ White Goods
- _ Medical

Part Number	Humidity Accuracy [%RH]	Temperature Accuracy[K] @25°C	Package
RHTS02	±4.5	±0.5	SMD
RHTS02A	±4.5	±0.5	4-pin DIP

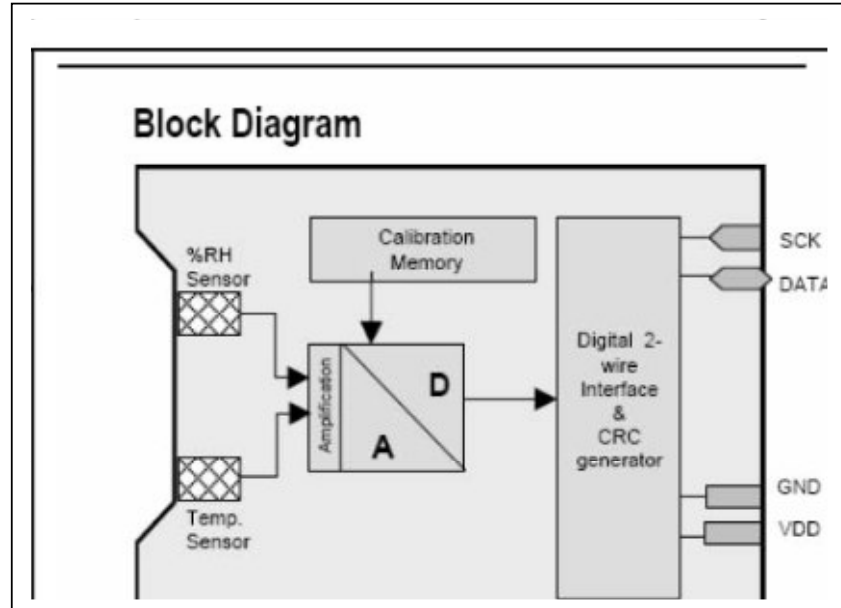

Package Information

1. RHTS02/02A (surface mountable)

Pin	Nam	Comment
1	DATA	Serial data,bidirectional
2	GND	Ground
3	VDD	Supply 2.4-5.5V
4	CLK	Serial clock,input
	NC	Remaining pins must be left unconnected

For manual soldering contact time must be limited to 5 seconds at up to 350

°C After soldering the devices should be stored at >74%RH for at least 24h to allow the polymer to rehydrate. Please consult the application note "Soldering procedure" for more information.

2.RHTSxx Pin Description 2 PCB Description

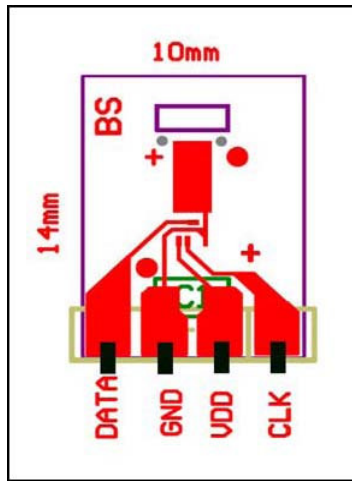

DIP package

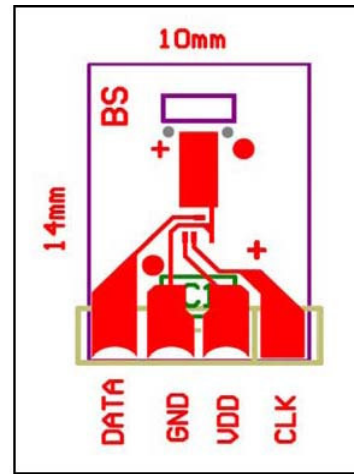

SMD package

1. Sensor Performance Specifications

Parameter	Conditions	Min.	Type.	Max.	Units
Humidity					
Resolution		0.5	0.03	0.03	%RH
		8	12	12	bit
Repeatability			±0.1		%RH
Accuracy Uncertainty	Linearized				
Interchangeability		Full Interchangeability			
Nonlinearity	Raw data		±3		%RH
	linearized		<<1		%RH
Range		0		100	%RH
Response Time	f/e(63%) Slowly moving air		4		s
Hysteresis			±		%RH
Long Term Stability	typical		<0.5		%RH/Yr
Temperataure					
Resolution		0.04	0.01	0.01	°C
		0.07	0.02	0.02	°F
		12	14	14	bit
Repeatablity		±0.1			°C
		±0.2			°F

Accuracy					
Range		-40		123.8	°C
		-40		254.9	°F
Response Time	1/e(63%)	5		30	s

2. Interface Specifications

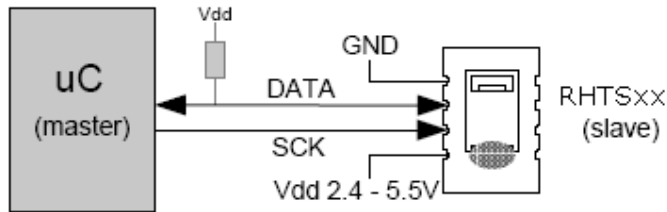

Figure 2 Typical application circuit

2.1 Power Pins

The RHTSxx requires a voltage supply between 2.4 and 5.5V. After Powerup the device needs 11ms to reach its “sleep” state.No commands should be sent before that time. Power supply pins(VDD,GND) may be decoupled with a 100 nF capacitor.

2.2 Serial Interface(Bidirectional 2-wire)

The serial interface of the RHTSxx is optimized for sensor readout and power consumption and is not compatible with I²C interfaces, see FAQ for details.

2.2.1 Serial clock input(SCK)

The SCK is used to synchronize the communication between a microcontroller and the the RHTSxx. Since the interface consists of fully static logic there is no minimum SCK frequency.

2.2.2 Serial data(DATA)

The DATA tristate pin is used to transfer data in and out of the device.DATA changes after the falling edge and is valid on the rising dege of the serial clock SCK. During transmission the DATA line must remain stable while SCK is high.To avoid signal contention the microcontroller should only drive DATA low.An external pull-up resistor (e.g. 10kΩ) is required to pull the signal high. Pull-up resistors are often included in I/O circuits of microcontrollers. See Table 5 for detailed IO characteristics.

- 1) Each RHTSxx is tested to be fully within RH accuracy specifications at 25 °C (77 °F) and 48 °C (118.4 °F)
- (2) The default measurement resolution of 14bit (temperature) and 12bit (humidity) can be reduced to 12 and 8 bit through the status register.

2.2.2 Sending a command

To initiate a transmission, a “Transmission Start” sequence has to be issued. It consists of a lowering of the DATA line while SCK is high, followed by a low pulse on SCK and raising DATA again while SCK is still high.

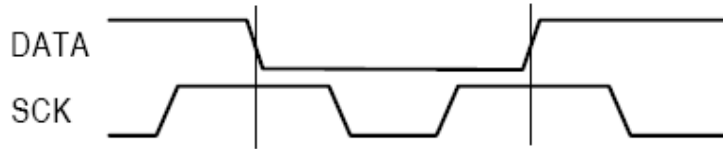

Figure 3 "Transmission Start" sequence

The subsequent command consists of three address bits (only “000” is currently supported) and five command bits. The RHTSxx indicates the proper reception of a command by pulling the DATA pin low (ACK bit) after the falling edge of the 8th SCK clock. The DATA line is released (and goes high) after the falling edge of the 9th SCK clock.

Command	Code
Reserved	0000x
Measure Temperature	00011
Measure Humidity	00101
Read Status Register	00111
Write Status Register	00110
Reserved	0101x-1110x
Soft reset , resets the interface, clears the status register to default values wait minimum 11 ms before next command	11110

Table 2 RHTSxx LIST OF COMMANDS

2.2.3 Measurement sequence (RH and T)

After issuing a measurement command (‘00000101’ for RH, ‘00000011’ for Temperature) the controller has to wait for the measurement to complete. This takes approximately 11/55/210 ms for a 8/12/14bit measurement. The exact time varies by up to $\pm 15\%$ with the speed of the internal oscillator. To signal the completion of a measurement, the RHTSxx pulls down the data line and enters idle mode. The controller must wait for this “data ready” signal before restarting SCK to readout the data. Measurement data is stored until readout, therefore the controller can continue with other tasks and readout as convenient.

Two bytes of measurement data and one byte of CRC checksum will then be transmitted. The uC must acknowledge each byte by pulling the DATA line low. All values are MSB first, right justified. (e.g. the 5th SCK is MSB for a 12bit value, for a 8bit result the first byte is not used). Communication terminates

after the acknowledge bit of the CRC data. If CRC-8 checksum is not used the controller may terminate the communication after the measurement data LSB by keeping ack high. The device automatically returns to sleep mode after the measurement and communication have ended. Warning: To keep self heating below 0.1 °C the RHTSxx should not be active for more than 10% of the time (e.g. max. 2 measurements / second for 12bit accuracy).

2.2.5 Connection reset sequence

If communication with the device is lost the following signal sequence will reset its serial interface: While leaving DATA high, toggle SCK 9 or more times. This must be followed by a “Transmission Start” sequence preceding the next command. This sequence resets the interface only. The status register preserves its content.

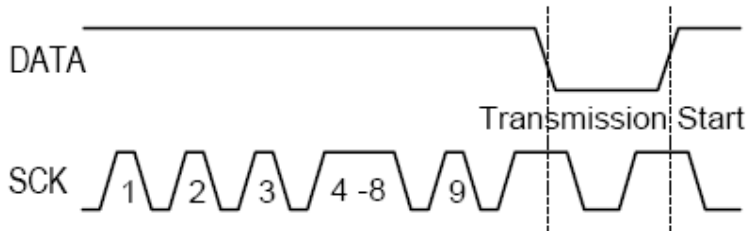

Figure 4 Connection reset sequence

2.2.6 CRC-8 Checksum calculation

The whole digital transmission is secured by a 8 bit checksum. It ensures that any wrong data can be detected and eliminated. Please consult application note “CRC-8 Checksum Calculation” for information on how to calculate the CRC. (See CRC_calculation on page 15)

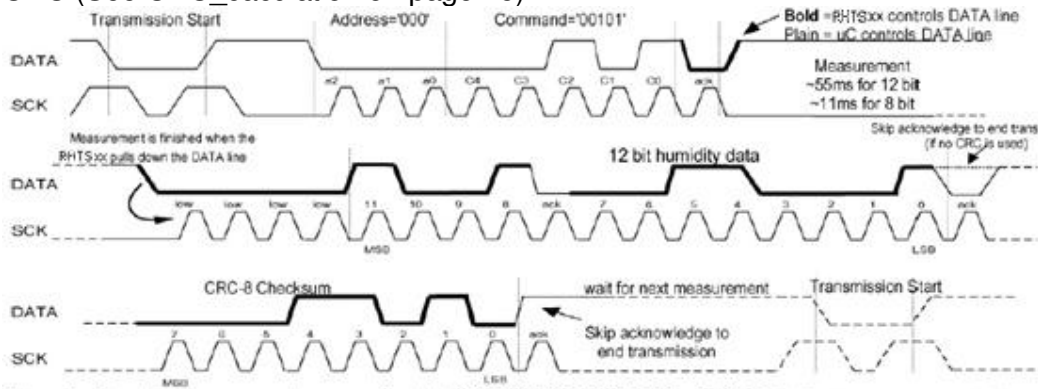

Figure 5 Example RH measurement sequence for value '0000'1001' 0011'0001' = 2353 = 75.79 %RH (without temperature compensation)

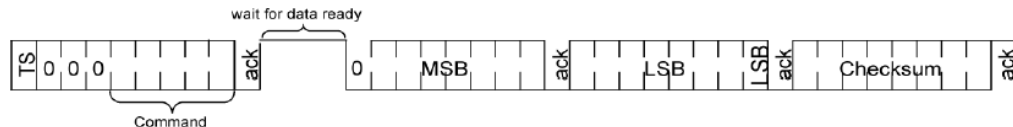

Figure 6 Overview of Measurement Sequence (TS = Transmission Start)

2.3 Status Register

Some of the advanced functions of the RHTSxx are available through the

status register. The following section gives a brief overview of these features. A more detailed description is available in the application note “Status Register”

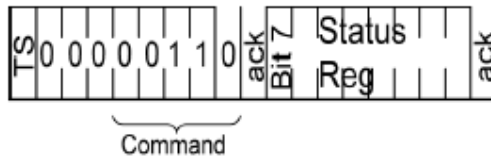

Figure 7 Status Register Write

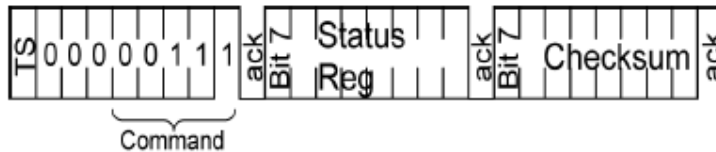

Figure 8 Status Register Read

Bit	Type	Description	Default	
7		reserved	0	
6	R	End of Battery(low voltage detection) "0" for Vdd>2.47 "1" for Vdd<2.47	X	No default value, bit is only updated after a measurement
5		reserved	0	
4		Reserved	0	
3		For Testing only, do not use	0	
2	R/W	Heater	0	off
1	R/W	No reload from OTP	0	Reload
0	R/W	'1'=8bit RH/12bit temperature resolution	0	12bit RH

Table 3 Status Register Bits

2.3.1 Measurement resolution

The default measurement resolution of 14bit (temperature) and 12bit (humidity) can be reduced to 12 and 8bit. This is especially useful in high speed or extreme low power applications.

2.3.2 End of Battery The “End of Battery” function detects VDD voltages below 2.47 V. Accuracy is ± 0.05 V

2.3.3 Heater An on chip heating element can be switched on. It will increase the temperature of the sensor by 5-15 °C (9-27 °F). Power consumption will increase by ~8 mA @ 5 V. Applications: By comparing temperature and humidity values before and after switching on the heater, proper functionality of both sensors can be verified. • In high (>95 %RH) RH environments heating the sensor element will prevent condensation, improve response time and accuracy Warning: While heated the RHTSxx will show higher temperatures and a lower relative humidity than with no heating.

2.4 Electrical Characteristics

(1) VDD=5V, Temperature = 25 °C unless otherwise noted.

Parameter	Conditions	Min.	Typ.	Max.	Units
Power supply DC		2.4	5	5.5	V
Supply current	measuring		550		μA
	average	2 ⁽²⁾	28 ⁽³⁾		μA
	sleep		0.3	1	μA
Low level output voltage		0		20%	Vdd
High level output voltage		75%		100%	Vdd
Low level input voltage	Negative going	0		20%	Vdd
High level input voltage	Positive going	80%		100%	Vdd
Input current on pads				1	μA
Output peak current	on			4	mA
	Tristated (off)		10		μA

Table 4 RHTSxx DC Characteristics

	Parameter	Conditions	Min	Typ.	Max.	Unit
F _{SCK}	SCK frequency	VDD > 4.5 V			10	MHz
		VDD < 4.5 V			1	MHz
T _{RFO}	DATA fall time	Output load 5 pF	3.5	10	20	ns
		Output load 100 pF	30	40	200	ns
T _{CLx}	SCK hi/low time		100			ns
T _V	DATA valid time			250		ns
T _{SU}	DATA set up time		100			ns
T _{HO}	DATA hold time		0	10		ns
T _r /T _f	SCK rise/fall time			200		ns

Table 5 RHTSxx I/O Signals Characteristics

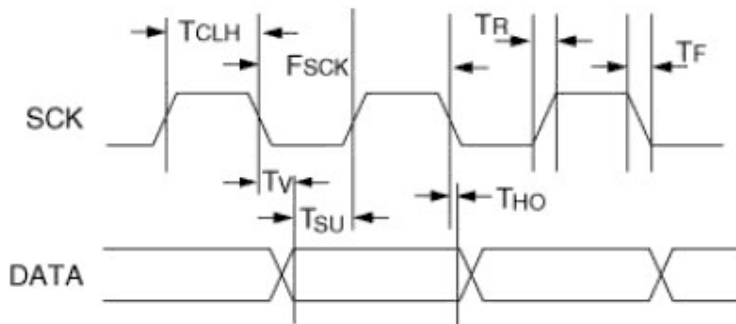

Figure 9 Timing Diagram

3 Converting Output to Physical Values

3.1 Relative Humidity

To compensate for the non-linearity of the humidity sensor and to obtain the full accuracy it is recommended to convert the readout with the following formula1:

$$RH_{\text{linear}} = c_1 + c_2 \cdot SO_{RH} + c_3 \cdot SO_{RH}^2$$

SO _{RH}	C1	C2	C3
8bit	-4	0.648	-7.2*10 ⁻⁴

Table 6 Humidity conversion coefficients

For simplified, less computation intense conversion formulas see application note “RH and Temperature Non-Linearity Compensation”. Values higher than 99% RH indicate fully saturated air and must be processed and displayed as 100% RH. The humidity sensor has no significant voltage dependency.

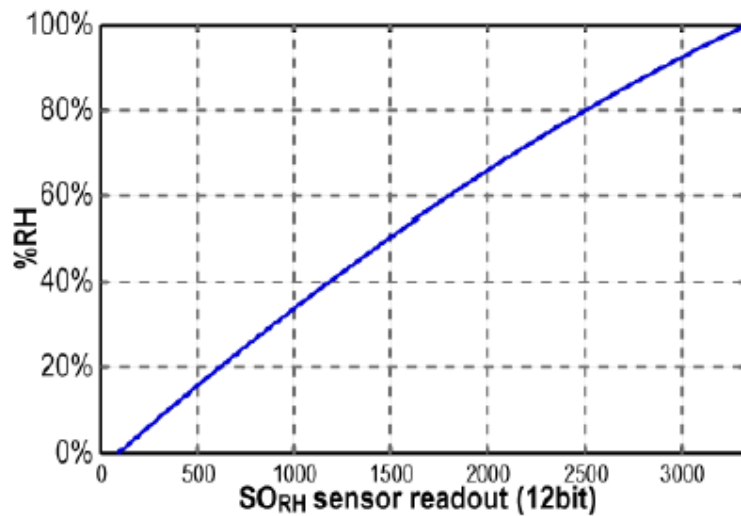
Figure 10 Conversion from SO_{RH} to relative humidity

3.1.1 Humidity Sensor RH/Temperature compensation For temperatures significantly different from 25 °C (~77 °F) the temperature coefficient of the RH sensor should be considered:

$$RH_{\text{true}} = (T_{\text{c}} - 25) \cdot (t_1 + t_2 \cdot SO_{\text{RH}}) + RH_{\text{linear}}$$

SO _{RH}	t1	t2
8bit	0.01	0.00008

Table 7 Temperature compensation coefficients

This equals ~0.12 %RH / °C @ 50 %RH

3.2 Temperature

The bandgap PTAT (Proportional To Absolute Temperature) temperature sensor is very linear by design. Use the following formula to convert from digital readout to temperature:

$$\text{Temperature} = d_1 + d_2 \cdot SO_T$$

VDD	d ₁ [°C]	d ₁ [°F]
5V	-40.00	-40.00
4V	-39.75	-39.50
3.5V	-39.66	-39.35
3V	-39.60	-39.28
2.5V	-39.55	-39.23

Table 8 Temperature conversion coefficients

	D2(°C)	D2(°F)
12bit	0.04	0.072

For improved accuracies in extreme temperatures with more computation intense conversion formulas see application note “RH and Temperature Non-Linearity Compensation”.

3.3 Dewpoint

Since humidity and temperature are both measured on the same monolithic chip, the RHTSxx allows superb dewpoint measurements. See application note “Dewpoint calculation” for more.

4 Applications Information

4.1 Operating and Storage Conditions

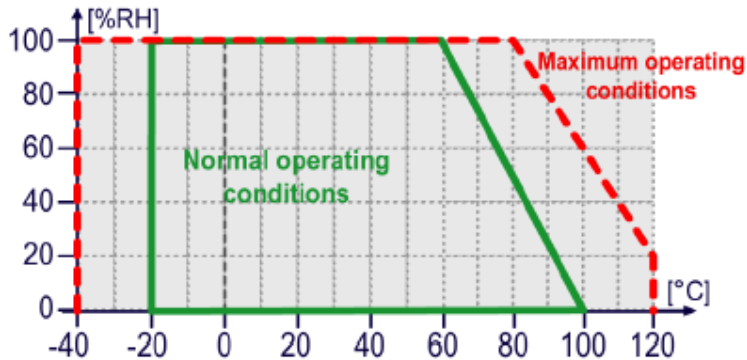

Figure 11 Recommended operating conditions

Conditions outside the recommended range may temporarily offset the RH signal up to ± 3 %RH. After return to normal conditions it will slowly return towards calibration state by itself. See 4.3 “Reconditioning Procedure” to accelerate this process. Prolonged exposure to extreme conditions may accelerate ageing.

4.2 Exposure to Chemicals

Chemical vapors may interfere with the polymer layers used for capacitive humidity sensors. The diffusion of chemicals into the polymer may cause a shift in both offset and sensitivity. In a clean environment the contaminants will slowly outgas. The reconditioning procedure described below will accelerate this process. High levels of pollutants may cause permanent damage to the sensing polymer.

4.3 Reconditioning Procedure

The following reconditioning procedure will bring the sensor back to calibration state after exposure to extreme conditions or chemical vapors. 80-90 °C (176-194 °F) at < 5 %RH for 24h (baking) followed by 20-30 °C (70-90 °F) at > 74 %RH for 48h (re-hydration)

4.4 Temperature Effects

The relative humidity of a gas strongly depends on its temperature. It is therefore essential to keep humidity sensors at the same temperature as the air of which the relative humidity is to be measured. If the RHTSxx shares a PCB with electronic components that give off heat it should be mounted far away and below the heat source and the housing must remain well ventilated. To reduce heat conduction copper layers between the RHTS1x and the rest of the PCB should be minimized and a slit may be milled in between (see figure 13).

4.5 Membranes

A membrane may be used to prevent dirt from entering the housing and to protect the sensor. It will also reduce peak concentrations of chemical vapors. For optimal response times air volume behind the membrane must be kept to a minimum. For the RHTS1x package SENSLED recommends the SF1 filter cap for optimal IP67 protection.

4.6 Light

The RHTSxx is not light sensitive. Prolonged direct exposure to sunshine or strong UV radiation may age the housing.

4.7 Materials Used for Sealing / Mounting

Many materials absorb humidity and will act as a buffer, increasing response times and hysteresis. Materials in the vicinity of the sensor must therefore be carefully chosen. Recommended materials are: All Metals, LCP, POM (Delrin), PTFE (Teflon), PE, PEEK, PP, PB, PPS, PSU, PVDF, PVF For sealing and gluing (use sparingly): High filled epoxy for electronic packaging (e.g. glob top, underfill), and Silicone. Outgassing of these materials may also contaminate the RHTSxx (cf. 4.2). Store well ventilated after manufacturing or bake at 50 °C for 24h to outgas contaminants before packing.

4.8 Wiring Considerations and Signal Integrity

Carrying the SCK and DATA signal parallel and in close proximity (e.g. in wires) for more than 10cm may result in cross talk and loss of communication. This may be resolved by routing VDD and/or GND between the two data signals. Please see the application note “ESD, Latchup and EMC” for more information. Power supply pins (VDD, GND) should be decoupled with a 100 nF capacitor if wires are used.

4.9 Qualifications

Extensive tests were performed in various environments. Please contact SENSLED for detailed information.

Environment	Norm	Results ⁽¹⁾
Temperature Cycles	JESD22-A104-B -40 °C / 125 °C, 1000 cy	Within Specifications
HAST Pressure Cooker	JESD22-A110-B 2.3 bar 125 °C 85 %RH	Reversible shift by +2 %RH
High Temperature and Humidity	JESD22-A101-B 85 °C 85 %RH 1250h	Reversible shift by +2 %RH
Salt Atmosphere	DIN-50021ss	Within Spec.
Condensing Air	-	Within Spec.
Freezing cycles fully submerged	-20 / +90 °C, 100 cy 30min dwell time	Reversible shift by +2 %RH
Various Automotive Chemicals	DIN 72300-5	Within Specifications

Table 9 Qualification tests (excerpt)

4.10 ESD (Electrostatic Discharge)

ESD immunity is qualified according to MIL STD 883E, method 3015 (Human Body Model at ± 2 kV)). Latch-up immunity is provided at a force current of ± 100 mA with $T_{amb} = 80$ °C according to JEDEC 17. See application note “ESD, Latchup and EMC” for more information.

The RHTSx is supplied in a surface-mountable LCC (Leadless Chip Carrier) type package. The sensors housing consists of a Liquid Crystal Polymer (LCP) cap with epoxy glob top on a standard 0.8 mm FR4 substrate. The device is free of Pb, Cd and Hg. (Fully ROHS, WEEE compliant)

5 Package Information

5.1.3 Soldering Information Standard reflow soldering ovens may be used. For details please see application note “soldering procedure”.

For manual soldering contact time must be limited to 5 seconds at up to 350 °C. After soldering the devices should be stored at >74 %RH for at least 24h to allow the polymer to rehydrate. Please consult the application note “Soldering procedure” for more information.

5.2.1 Package type

The device is supplied in a single-in-line pin type package. The sensor housing consists of a Liquid Crystal Polymer (LCP) cap with epoxy glob top on a standard 0.6 mm FR4 substrate. The device is Cd and Hg free. The sensor head is connected to the pins by a small bridge to minimize heat conduction and response times. The gold plated back side of the sensor head is connected to the GND pin. A 100nF capacitor is mounted on the back side between VDD and GND. All pins are gold plated to avoid corrosion.

6.Important Notices

6.1 Warning, personal injury

Do not use this product as safety or emergency stop devices or in any other application where failure of the product could result in personal injury. Failure to comply with these instructions could result in death or serious injury. Should buyer purchase or use SENSLED products for any such unintended or unauthorized application, Buyer shall indemnify and hold SENSLED and its officers, employees, subsidiaries, affiliates and distributors harmless against all claims, costs, damages and expenses, and reasonable attorney fees arising out of, directly or indirectly, any claim of personal injury or death associated with such unintended or unauthorized use, even if such claim alleges that SENSLED was negligent regarding the design or manufacture of the part.

6.2 ESD Precautions

The inherent design of this component causes it to be sensitive to electrostatic discharge (ESD). To prevent ESD-induced damage and/or degradation, take normal ESD precautions when handling this product. See application note "ESD, Latchup and EMC" for more information.

6.3 Warranty

SENSLED makes no warranty, representation or guarantee regarding the suitability of its product for any particular purpose, nor does SENSLED assume any liability arising out of the application or use of any product or circuit and specifically disclaims any and all liability, including without limitation consequential or incidental damages. "Typical" parameters can and do vary in different applications. All operating parameters, including "Typical" must be validated for each customer applications by customer's technical experts. SENSLED reserves the right, without further notice, to change the product specifications and/or information in this document and to improve reliability, functions and design.

RHTS02/02A

Humidity & Temperature
Sensmitter

Application Note CRC

1 Introduction

A CRC checksum is calculated over the whole transmission. If a CRC mismatch is detected, the RHTSxx should be reset (command "00011110") and the measurement should be repeated.

2 Theory

CRC stands for Cyclic Redundancy Check. It is one of the most effective error detection schemes and requires a minimal amount of hardware.

For in-depth information on CRC we recommend the comprehensive: ["A painless guide to CRC error detection algorithms"](#)

The polynomial used in the RHTSxx is: $x^8 + x^5 + x^4$. The types of errors that are detectable with this polynomial are:

1. Any odd number of errors anywhere within the transmission.
2. All double-bit errors anywhere within the transmission.
3. Any cluster of errors that can be contained within an 8-bit "window" (1-8 bits incorrect).
4. Most larger clusters of errors.

The CRC register initializes with the value of the lower nibble of the status register ("0000's₃s₂s₁s₀", default "00000000"). It covers the whole transmission (command and response bytes) without the acknowledge bits. See the datasheet RHTSXX on page 4 for an example of CRC readout.

The receiver can perform the CRC calculation upon the first part of the original message and then compare the result with the received CRC- 8. If a CRC mismatch is detected, the RHTSxx should be reset (command "00011110") and the measurement should be repeated.

This application note will cover two methods for checking the CRC. The first "Bitwise" is more suited for hardware or lowlevel implementation while the later "Bytewise" is the preferred method for more powerful microcontroller solutions.

2.1 Bitwise

With the bitwise method, the receiver copies the structure of the CRC generator in hard- or software. An algorithm to calculate this could look like this:

- 1) Initialise CRC Register to low nibble of status register (reversed (s₀s₁s₂s₃'0000))
- 2) Compare each (transmitted and received) bit with bit 7
- 3) If the same: shift CRC register, bit0='0'
else: shift CRC register and then invert bit4 and bit5, bit0='1' (see figure 1)
- 4) receive new bit and go to 2)
- 5) The CRC value retrieved from the RHTSxx must be reversed (bit 0 = bit 7, bit 1=bit 6 ... bit 7 = bit 0) and can then be compared to the final CRC value.⁽²⁾

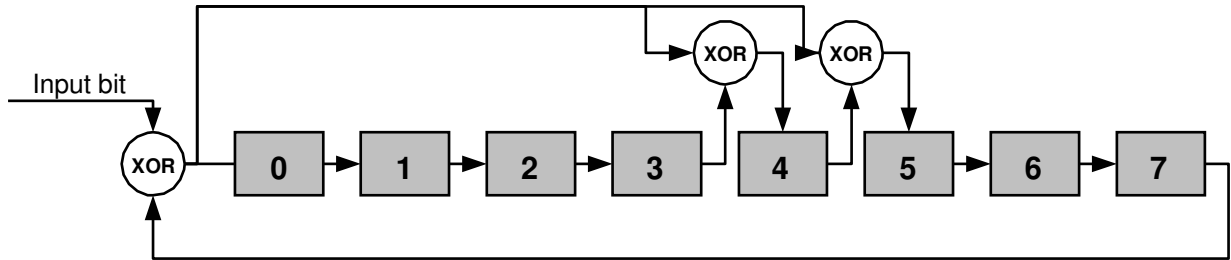

Figure 1 Internal structure of the RHTSxx CRC-8 generator

2.1.1 Example for bitwise

Example 2: RH Measurement (as example in datasheet)

Input bit's	bit7 ... bit0	0x	dec	Comment
	0000'0000	0x		Start value see below ⁽¹⁾
0	0000'0000	00	0	1 st bit of command
0	0000'0000	00	0	2 nd bit of command
0	0000'0000	00	0	...
0	0000'0000	00	0	
1	0011'0001			CRC EXOR polynom
0	0110'0010			
1	1111'0101	F5	245	CRC after command
0	1101'1011			1 st byte (MSB) of measurement
0	1000'0111			
0	0011'1111			
0	0111'1110			
1	1100'1101			
0	1010'1011			
0	0110'0111			
1	1111'1111	FF	255	CRC value
0	1100'1111			2 nd byte (LSB) of measurement
0	1010'1111			
1	0101'1110			
1	1000'1101			
0	0010'1011			
0	0101'0110			
0	1010'1100			
1	0101'1000	58	88	Final CRC value

Example 1: readout of status register containing 0x40

Input bit's	bit7 ... bit0	0x	dec	Comment
	0000'0000	0x		Start value see below ⁽¹⁾
0	0000'0000	00	0	1 st bit of command
0	0000'0000	00	0	2 nd bit of command
0	0000'0000	00	0	...
0	0000'0000	00	0	
0	0000'0000	00	0	
1	0011'0001			CRC EXOR polynom
1	0101'0011			
1	1001'0111	97	151	CRC after command
0	0001'1111			1 st bit (MSB) of status register
1	0000'1111			
0	0001'1110			
0	0011'1100			
0	0111'1000			
0	1111'0000			
0	1101'0001			
0	1001'0011	93	147	Final CRC value

(1) Low nibble only, whole byte reversed (Statusregister = [s₇s₆s₅s₄'s₃s₂s₁s₀] -> Startvalue = [s₀s₁s₂s₃'0000])

(2) This is different to other CRC implementations

2.2 Bytewise

With this implementation the CRC data is stored in a 256 byte lookup table.

Perform the following operations:

1. Initialize the CRC register with the value of the lower nibble of the value of the status register (reversed (s₀s₁s₂s₃'0000)). (default '00000000' = 0)
2. XOR each (transmitted and received) byte with the previous CRC value.
The result is the new byte that you need to calculate the CRC value from.
3. Use this value as the index to the table to obtain the new CRC value.
4. Repeat from 2.) until you have passed all bytes through the process.
5. The last byte retrieved from the table is the final CRC value.
6. The CRC value retrieved from the SHTxx must be reversed (bit 0 = bit 7, bit 1=bit 6 ... bit 7 = bit 0) and can then be compared to the final CRC value.⁽²⁾

2.2.1 256 byte CRC Lookup table

0	1	2	3	4	5	6	7	8	9	10	11	12	13	14	15	16	17	18	19	20	21	22	23	24	25	26	27	28	29	30	31
0	49	98	83	196	245	166	151	185	136	219	234	125	76	31	46	67	114	33	16	135	182	229	212	250	203	152	169	62	15	92	109
32	33	34	35	36	37	38	39	40	41	42	43	44	45	46	47	48	49	50	51	52	53	54	55	56	57	58	59	60	61	62	63
134	183	228	213	66	115	32	17	63	14	93	108	251	202	153	168	197	244	167	150	1	48	99	82	124	77	30	47	184	137	218	235
64	65	66	67	68	69	70	71	72	73	74	75	76	77	78	79	80	81	82	83	84	85	86	87	88	89	90	91	92	93	94	95
61	12	95	110	249	200	155	170	132	181	230	215	64	113	34	19	126	79	28	45	186	139	216	233	199	246	165	148	3	50	97	80
96	97	98	99	100	101	102	103	104	105	106	107	108	109	110	111	112	113	114	115	116	117	118	119	120	121	122	123	124	125	126	127
187	138	217	232	127	78	29	44	2	51	96	81	198	247	164	149	248	201	154	171	60	13	94	111	65	112	35	18	133	180	231	214
128	129	130	131	132	133	134	135	136	137	138	139	140	141	142	143	144	145	146	147	148	149	150	151	152	153	154	155	156	157	158	159
122	75	24	41	190	143	220	237	195	242	161	144	7	54	101	84	57	8	91	106	253	204	159	174	128	177	226	211	68	117	38	23
160	161	162	163	164	165	166	167	168	169	170	171	172	173	174	175	176	177	178	179	180	181	182	183	184	185	186	187	188	189	190	191
252	205	158	175	56	9	90	107	69	116	39	22	129	176	227	210	191	142	221	236	123	74	25	40	6	55	100	85	194	243	160	145
192	193	194	195	196	197	198	199	200	201	202	203	204	205	206	207	208	209	210	211	212	213	214	215	216	217	218	219	220	221	222	223
71	118	37	20	131	178	225	208	254	207	156	173	58	11	88	105	4	53	102	87	192	241	162	147	189	140	223	238	121	72	27	42
224	225	226	227	228	229	230	231	232	233	234	235	236	237	238	239	240	241	242	243	244	245	246	247	248	249	250	251	252	253	254	255
193	240	163	146	5	52	103	86	120	73	26	43	188	141	222	239	130	179	224	209	70	119	36	21	59	10	89	104	255	206	157	172

(2) This is different to other CRC implementations

2.2.2 Code example for lookup table

The following procedure calculates the CRC-8. The result accumulates in the variable CRC.

```

Var
CRC : Byte;
Procedure calc_CRC(X: Byte);

Const
CRC_Table : Array[0..255] of Byte = (
0, 49, 98, 83, 196, 245, 166, 151, 185, 136, 219, 234, 125, 76, 31, 46, 67, 114, 33, 16,
135, 182, 229, 212, 250, 203, 152, 169, 62, 15, 92, 109, 134, 183, 228, 213, 66, 115, 32, 17,
63, 14, 93, 108, 251, 202, 153, 168, 197, 244, 167, 150, 1, 48, 99, 82, 124, 77, 30, 47,
184, 137, 218, 235, 61, 12, 95, 110, 249, 200, 155, 170, 132, 181, 230, 215, 64, 113, 34, 19,
126, 79, 28, 45, 186, 139, 216, 233, 199, 246, 165, 148, 3, 50, 97, 80, 187, 138, 217, 232,
127, 78, 29, 44, 2, 51, 96, 81, 198, 247, 164, 149, 248, 201, 154, 171, 60, 13, 94, 111,
65, 112, 35, 18, 133, 180, 231, 214, 122, 75, 24, 41, 190, 143, 220, 237, 195, 242, 161, 144,
7, 54, 101, 84, 57, 8, 91, 106, 253, 204, 159, 174, 128, 177, 226, 211, 68, 117, 38, 23,
252, 205, 158, 175, 56, 9, 90, 107, 69, 116, 39, 22, 129, 176, 227, 210, 191, 142, 221, 236,
123, 74, 25, 40, 6, 55, 100, 85, 194, 243, 160, 145, 71, 118, 37, 20, 131, 178, 225, 208,
254, 207, 156, 173, 58, 11, 88, 105, 4, 53, 102, 87, 192, 241, 162, 147, 189, 140, 223, 238,
121, 72, 27, 42, 193, 240, 163, 146, 5, 52, 103, 86, 120, 73, 26, 43, 188, 141, 222, 239,
130, 179, 224, 209, 70, 119, 36, 21, 59, 10, 89, 104, 255, 206, 157, 172);

Begin
CRC := CRC_Table[X xor CRC];
End;

```

3 Revision history

e	Revision	
December 30, 2001	0.9 (Preliminary)	Initial revision
February 18, 2001	1.01	
February 27, 2001	1.02	corrected bug in CRC register init. (byte must be reversed)
May 16, 2002	1.03	emphasize that command to RHTSxx is also in CRC
Oct. 17, 2003	1.04	Changed download link
December 16, 2003	1.05	Improved bitwise example table
May 25, 2005	1.06	Changed company address